

# Marketing Information

John Deere Company

Date: 15 September 1983

Number: JDM-83-25i (Complete Goods)

To: All John Deere Consumer Products Dealers



## NEW QUIK-TATCH MODEL 44 LOADER FOR LAWN AND GARDEN TRACTORS



A new Model 44 Loader of quik-tatch design is available for the 316, 318, and 420 Lawn and Garden Tractors.

Your customers will appreciate the added flexibility that the quik-tatch feature alone offers, as it is not found on competitive loaders of this class.

The loader's lift capacity is 400 pounds mounted on the 316 and 318, and 500 pounds on the 420 Tractor, lifting to a full height of 73 inches.

To ensure good hydraulic performance, a four gallon per-minute front-mount PTO pump, along with separate valve and reservoir, is standard equipment.

The bucket selection includes a 48-inch bucket as standard equipment, and an optional 54-inch materials bucket. The bucket's top surface is parallel with the bottom, making it easier for the operator to judge the position of the bucket.

Other John Deere loader family features found on the Model 44 are:

- Tapered boom design ... for more strength, especially at cylinder connecting points.
- Patented torque tube ... to give extra structural rigidity to the loader boom.
- Quik-tatch mounting ... equip the Model 44 Loader with mounting stands (attachment) and, by simply removing the quick-release pins, the loader can be detached from the tractor. Removing the quick-couplers and backing away frees the tractor for other chores.
- Easy tractor servicing ... engine hood can be fully opened for servicing with the loader in the lowered position.
- Operator's platform ... full access to the operator's station from either the right or left side of the tractor.

Other attachments are the bucket level indicator and grille guard.

Availability: March 1984

MmrBeef

Specifications

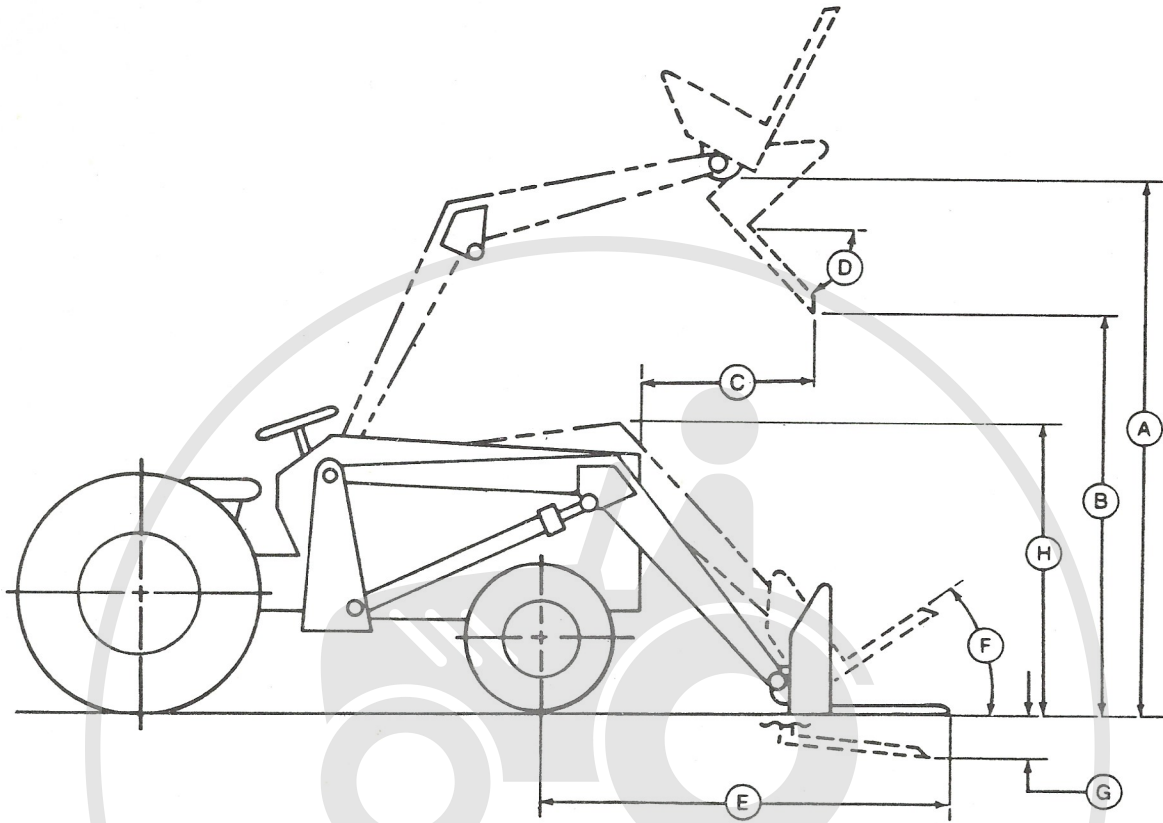

	<u>316/318</u>	<u>420</u>
A. Maximum Lift .....	73" (1.85 m)	73" (1.85 m)
B. Clearance with Attachment		
Dumped .....	53-1/4" (1.35 m)	53-1/4" (1.35 m)
C. Reach at Maximum Height ....	20-7/8" (530 mm)	20-7/8" (530 mm)
D. Maximum Dump Angle .....	50°	50°
E. Reach with Attachment on		
Ground .....	43-3/4" (1.11 m)	43-3/4" (1.11 m)
F. Attachment Rollback .....	20°	20°
G. Digging Depth .....	5" (127 mm)	5" (127 mm)
H. Overall Height in Carry		
Position .....	40" (1.02 m)	40" (1.02 m)
Approximate Lift Capacity ....	400# (182 kg)	500# (227 kg)

Specifications and design are subject to change without notice.

44 LOADER  
(Continued)

Code	Description		
BUCKETS			
3000	48-In. Bucket		In Base
3001	54-In. Materials Bucket	Add	
3002	Less Bucket	Deduct	

Attachments - Order As Desired

	<u>Attachment Identifier</u>	
9000	TY20048	Mounting Stand
9001	TY9586	Bucket Level Indicator
9002	TY20049	Grille Guard

Attachments For Field Conversion

TY20042	316 and 318 Mountings
TY20043	420 Mountings
TY20044	316 and 318 Hydraulics
TY20045	420 Hydraulics
TY20046	48-Inch Bucket
TY20047	54-Inch Bucket

## 44 LOADER

This is ordering information in price page format. Add this information to the appropriate section of your Consumer Products Price List. Destroy upon receipt of Price Information or new price page(s).

### Standard Equipment

73-In. (1.85 m) Lift Height • 400 Lbs. (182 kg) Lift Capacity on 316 and 318; 500 Lbs. (227 kg) on 420 Tractor • 48-In. Bucket • 4 gpm Hydraulic Pump, Hoses, and Dual Valve Included • Quik-Tatch Mounting • For Mounting on 316, 318, and 420 Tractors

NOTE: Tractor ballasting required; see operator's manual.

Code	Description
------	-------------

One Code Required From Each Box

#### BASE MACHINE

0461TY	44 Loader
--------	-----------

#### MOUNTINGS

1000	316 and 318 Lawn & Garden Tractors		In Base
1001	420 Lawn & Garden Tractors	Add	
1002	Less Mountings	Deduct	

#### HYDRAULICS

2001	316 and 318 Lawn & Garden Tractors Pump Valve and Reservoir		In Base
2002	420 Lawn & Garden Tractors Pump Valve and Reservoir	Add	
2003	Less Hydraulic Mounting	Deduct	